



# toolbox

NEW ZEALAND CRAFTSMAN TRAINING FOUNDATION (INC)

PO Box 49029, Mt Roskill South, Auckland. Tel: 09 414 2141 Fax: 09 414 2146

## Overseas Training Valuable for Both Winner and Employer

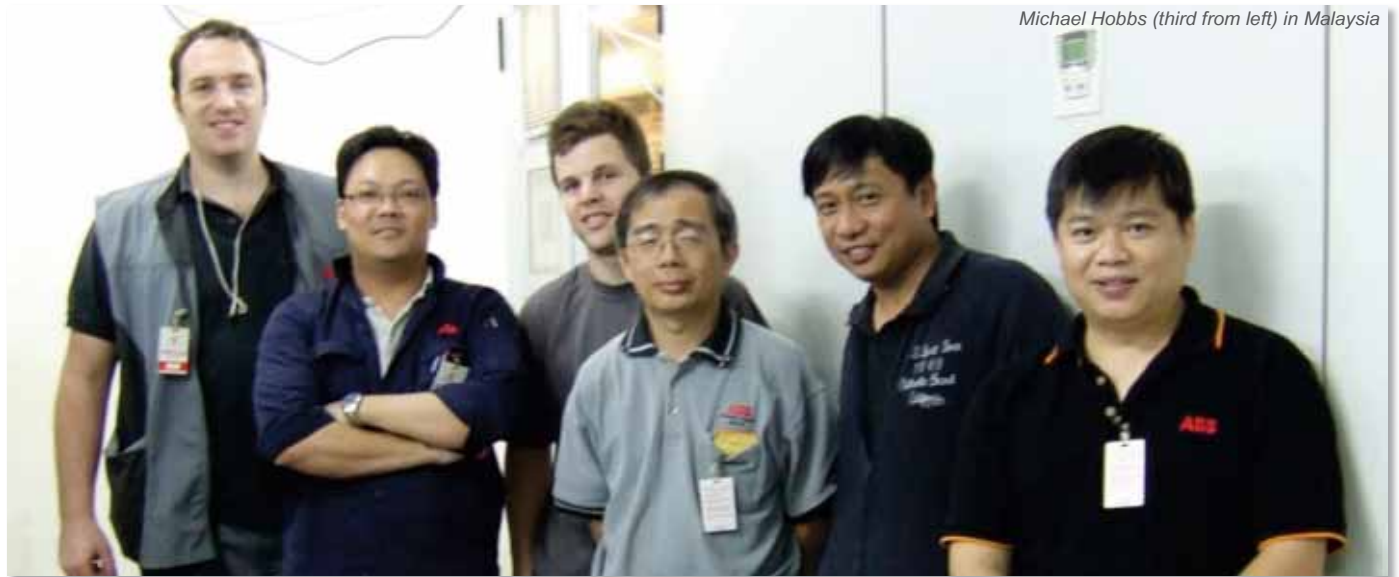

Michael Hobbs (third from left) in Malaysia

The winner of the 2008 short-term Overseas Training Award has described his recent a six-week trip to Malaysia and Australia as a valuable experience for both himself and his employer.

Registered electrician Michael Hobbs completed his apprenticeship at Hamilton's ABB and is now working to become a power technician, which involves testing and commissioning electrical power plant equipment in the generation industry.

The Overseas Training Award enabled ABB to provide Michael with hands-on industry power plant and HV (high voltage) electrical testing experience within their own worldwide company that he would not have been able to get in New Zealand.

Michael spent four weeks in Malaysia in April during the testing and commissioning of a major power plant refurbishment and then a further two weeks in Brisbane at a motor winding workshop where he was exposed to some new testing that will be useful for applications in New Zealand. The trip has also allowed Michael (and therefore ABB locally) to develop valuable contacts and relationships, which can be used for advice and queries. In a large global organisation like ABB finding the right people to talk to can be challenging and time consuming and Michael's trip will enable the business to leverage off these resources should work opportunities arise.

Michael says, "The trip was definitely beneficial. It broadened my mind, exposed me to new things that

I would probably never have been exposed to in New Zealand, and it has provided more project work opportunities for both myself and ABB."

"It was a great experience and I thoroughly enjoyed it."

NZCTF Chairman, Owen Embling says the benefits Michael gained during his overseas training trip are very much in line with what the Craftsman Training Foundation is aiming to achieve. Owen says, "Our goal is to help promising young tradespeople get exposed to new ideas and ways of doing things so they can benefit both their own careers and their employers' businesses in New Zealand by bringing back valuable international contacts and applying the specialist knowledge they've gained."

[www.convex.co.nz](http://www.convex.co.nz)

for **YOUR** innovative packaging solutions

# Overseas Industry Training Rated as Very Rewarding by Winner



**Evan Bradley, the recipient of our 2007 Overseas Training Award, outlines the benefits he received from his short-term industry training trip last year...**

As Convex's mechanical engineer I was lucky enough to be the recipient of the 2007 Overseas Training Award from the New Zealand Craftsman Training Foundation. I returned to New Zealand last year in October having spent four weeks in Malaysia and Germany where I attended Drupa, the world's largest printing trade fair.



*Alpine Series X Die head*

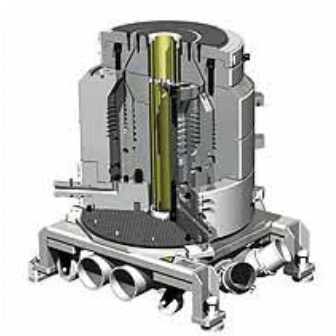

*Alpine Extruder*

DRUPA is held every four years at the Messe Dusseldorf in Germany and thousands of industry professionals and experts attend. The exhibition itself covers 16 hectares and lasts for over two weeks.

The experience was rewarding not only from a professional stand point but also the chance to see how the rest of the world functions and the way design and manufacturing is changed by social and economic diversities.

Whilst in Germany I visited Co-Extruder manufacturer Alpine Machine Co. and printing press manufacturer Windmoller

and Holscher who I believe have some of the best designers and machines in the world. Windmoller and Holscher have set ways of doing things that they won't deviate from but what they produce is an incredibly superior machine and product. The finish of the machinery is immaculate and the design is state of the art. I believe however that these designers are not super human and we should be able to emulate their innovation here in New Zealand.

One of the key design aspects that caught my eye were the Alpine Extruders, with their new die paths cut into the outer casing rather than the central shaft. They are easier to maintain and clean than existing models.

Another innovative solution were the print presses that I saw at Windmoller and Holscher. By upgrading to this new pump system we would cut our down time on a machine by one quarter and the maintenance checks we are currently doing could be done yearly rather than once a month.

An area that I can already see an improvement in at Convex is our number eight conversion machine. We have pulled the hot air sealing and put on seal heads with elements. This has sped up the process from 48 metres per minute to 60 metres per minute and created a far improved seal.

Going forward I believe that we as a company need to look back at our roots to see that Convex was built on innovation and design. If we continue to dedicate time and resources on development then we can attain the kind of results that the German suppliers have achieved.



*Windmoller and Holscher Printing press*

## Overseas Travel Opportunity for Keen Young Tradesperson

The New Zealand Craftsman Training Foundation (NZCTF) is offering their 2009 overseas travel award to the engineering maintenance and motor trades this year and is looking for a keen young tradesperson eager to advance their career.

Each year the NZCTF aims to assist a young person just starting out in their trade careers gain overseas industry skills and experience without leaving their jobs in New Zealand by offering an industry-focused travel award. The award targets a different industry groups each year, and this year it's the engineering maintenance and trades.

The applications for the 2009 award close on the 30th of September, and it's recipient will be announced in October.

You can find out more about the award and how to apply by visiting [www.craftsmantraining.co.nz](http://www.craftsmantraining.co.nz)

## Barry's 1908 Rover Restoration



Barry Robert, past chairman of the New Zealand Craftsman Training Foundation from 1986 to 1995, has just finished restoring a 1908 single cylinder Rover. He tells us how he did it...

In 1991 I obtained a 6-horse power single cylinder Rover engine and gearbox from a friend in Ward, Marlborough. I already had a front axle that matched the engine and a search was on worldwide for a rear axle. Nothing was found so a decision was made to copy the almost identical Rover in the Southward museum.

Many measurements, photos and drawings later, wooden patterns were made and aluminum castings were produced in an Auckland factory. I machined the castings in a friend's lathe and suitable gears were fitted. All the brake gear, drums, hubs etc were made from drawings of the Southward car. The chassis was made of ash timber, plated with steel on one side, and joined at the corners with steel plates. The body is all wood with a panel steel bulkhead between

the engine and the driver. The steering box is rack and pinion and this had to be made too - from the wood patterns, casting and machining. Wheels are wood spoked and were made by a specialist in Fielding who made them to fit the original size beaded edge tyres.

So why does a mechanical engineer spend his retirement years on so much woodwork? When it is all finished each piece is a work of art.

## 2010 Conference in Christchurch

The New Zealand Craftsman Training Foundation (NZCTF) 2010 conference is being held in Christchurch at the Holiday Inn On Avon in October next year.

The conference will be held from Friday the 29th to the morning of Sunday the 31st October 2010, and members are encouraged to set aside those dates.

Accommodation has been block booked and 30 rooms are available at \$125.00 for up to two people per night.

Members can book accommodation direct to the Holiday Inn now by emailing: [conf@holidayinnonavon.co.nz](mailto:conf@holidayinnonavon.co.nz)

# Memorials



## Dean Cadwallader

Dean was a baking and pastry cook apprentice with Meadowbake from 1987 to 1991 and won an NZCTF award in 1992. He found a position in Dortmund in Germany in a bakery specialising in Danish pastries and rye breads and had a varied experience with German foods and catering. Dean

returned to Meadowbake and later worked for Old Fashioned Foods as production manager and developed some of the Aunt Betty's products. Dean was aged 41 when he died of a heart condition in January this year.



## Jeremy Cook

Civil Aviation Authority (CAA) Airworthiness Inspector, Jeremy Cook, was killed in the Airbus A320 accident off the coast of southern France on 28 November 2008.

Jeremy, a past NZCTF Overseas Travel Award recipient, was one of seven persons on board the aircraft while the aircraft was engaged in an acceptance flight prior to coming back onto the New Zealand Register. Four other New Zealanders lost their lives on the flight – they were three engineers and a senior pilot from Air New Zealand. Jeremy was in France to issue the New Zealand Airworthiness Certificate to the aircraft on completion of all the certification requirements.

The Director of Civil Aviation, Steve Douglas, said the CAA staff were shocked and saddened to hear the news and extended the condolences of all staff to the Cook family at the time of their loss. He said that the CAA will provide all the moral and practical support that is required to help the Cook family in their time of need in coping with their loss.

Manager Aircraft Certification, Geoff Connor, said that Jeremy's loss has been a sad time for the Aircraft Certification Unit. "Jeremy was an aviation professional and a valued member of our team. He has had a long and interesting career in aviation and this knowledge, combined with his mature manner, made him particularly effective in upholding safety standards."

Jeremy joined the Civil Aviation Authority as an Airworthiness Inspector in April 2005. A Licensed Maintenance Engineer with an extensive background in aircraft and engine maintenance, his career includes time with Air Niugini in Papua New Guinea, Ansett New Zealand, and with the Christchurch Engine Centre. In his role at the CAA he travelled extensively, inspecting aircraft for entry into the New Zealand civil aviation system. Because of his previous work in industry and his CAA role, he was well known to many in the aviation industry. Although often working away from the office, he formed very strong relationships within the CAA.

*Memorial reprinted with permission from the Civil Aviation Authority magazine, Vector*

## River Estate olive oil 'From Tree to Table'

River Estate is a boutique producer of premium New Zealand extra virgin olive oil and is a 'single estate' olive oil producer. We grow the olives and press them on site, at our grove in Whitford, thereby maintaining fresh high quality olive oil. No other olives from other groves are purchased or are introduced into our selection of olive oils.

Olives are cold pressed on same day as harvesting whenever practical, with a maximum period of 24 hours between harvesting to pressing, to maintain the extra freshness of the olive oil. Our grove is pesticide and herbicide free, closely following organic farming principles.

Oil flavours range from mild to semi-fruity to fruity. These are delicate oils, rather than intense, as we choose to harvest the olives in a ripe condition, as opposed to picking green.

We are located approximately 30 minutes from both central Auckland city and Auckland International Airport, on the tranquil banks of the Turanga River, Whitford.



**River Estate Award Winning 2008 Oils** River Estate **Koroneiki** and the **Picual** were both awarded **Bronze** medals in the **New Zealand Gourmet Oil Competition** also in October 2008.



River Estate **Tuscan Blend** and the **Chemlali** olive oils were both awarded **Silver** medals at the **OlivesNZ Awards** in October 2008.



We encourage you to taste our NZ fresh cold pressed extra virgin olive oils.

River Estate is located at 152 Wades Road, Whitford.

For all enquiries phone 09 530 9180  
Fax 09 530 9182  
email: oliveoil@ihug.co.nz

[www.RiverEstate.co.nz](http://www.RiverEstate.co.nz)

For more information please visit our website [www.craftsmantraining.co.nz](http://www.craftsmantraining.co.nz)